

Rapiscan 515



The **Rapiscan Model 515** is an x-ray security inspection system designed for customers with new and expanding security requirements. The Model 515 has a fully configurable technology menu, which allows the user to choose the best value for their application and budget. Its compact design and removable control panel make the system an excellent choice for numerous security applications. The system offers a tunnel opening of 640mm (25.2 inches) wide by 430mm (16.9 inches) high to accommodate large package sizes.

Intel Pentium® computer technology is the driving force in all of our developments. The **Model 515** base configuration includes multi-energy technology with the following standard features: Crystal Clear™, Density Threat Alert, Edge Enhancement, Variable Gamma, Inverse Video, Organic/Inorganic Stripping, Pseudo Color and Variable Zoom.

The **Model 515** may also be configured with the following advanced options:

Enhanced Performance X-ray (EPX): EPX enables rapid and consistent detection capability, identifying materials having specific characteristics of explosives and narcotics. Gold, currency and agricultural products can also be identified using EPX.

Threat Image Projection (TIP): Provides real time operator training and performance monitoring. The system inserts threat objects at predefined settings and intervals, into otherwise clean bags allowing supervisors to monitor operator's response. Multiple language choices are available for on screen dialogue with the operator.

The **Model 515** is part of the Rapiscan 500 Series product design, which offers a wide range of product configurations. We invite you to contact your sales representative for additional information.

Rapiscan Security Products

RAPISCAN

An **OSI** SYSTEMS Company

Rapiscan 515 Specifications

PHYSICAL SPECIFICATIONS

Dimensions: Length: 2016mm (79.37 in.)
 Height: 1347mm (53.03 in.)*
 Width: 831mm (32.72 in.)
 Tunnel Size: 640mm (W) x 430mm (H). (25.20 x 16.93 in.)
 Conveyor Speed: 0.22 M/Sec (44ft/min)
 Conveyor Load: 165Kg (365 lbs) evenly distributed
 Approx Weight: Net: 550 Kg (1210 lbs)
 Gross: 750 Kg (1650 lbs)
 Unit is mounted on heavy duty castors for ease of movement
 * Nominal height +1 inch adjustment

GENERAL

Resolution: 38 AWG guaranteed, 40 AWG typical
 Penetration: 27mm steel guaranteed, 29mm typical
 Material Separation: Low Z, Medium Z, High Z to 0.5 Z accuracy
 Monitor: 17-inch XVGA color, high refresh, non flicker
 Power: 115 VAC +/- 10%/60Hz/10 Amps or
 230 VAC +/- 10%/50Hz/5 Amps

X-RAY GENERATOR

Cooling: Sealed oil bath with forced air
 Anode Voltage: 160KV rated, operating @ 140KV
 Tube Current: 0.7 mA typical
 Orientation: Vertically Upward

COMPUTER SPECIFICATIONS

Processor Speed: Intel Pentium® Processor currently available
 Memory: 64 MB RAM minimum
 Video Memory: 16 MB minimum
 Hard Disk Drive: 20 GB minimum
 CD-ROM Drive: 40X Max Variable
 Floppy Disk: 1.44 MB

ENVIRONMENTAL REQUIREMENTS

Storage Temperature: -20°C to 50°C
 Operating Temperature: 0°C to 40°C
 Relative Humidity: 5 to 95% non-condensing

HEALTH & SAFETY

All Rapiscan systems comply with applicable international health and safety regulations including USA FDA X-ray systems (Federal Standard 21-CFR 1020.40) and Health and Safety at Work Act 1974-section 6, Amended by the Consumer Protection Act 1987. Maximum leakage radiation less than 0.1mR/hr (1µ Sv/hr) in contact with outer panels. Film Safety: For ISO 1600/33 DIN, guaranteed up to 10 times exposure to radiation.

DIMENSIONS

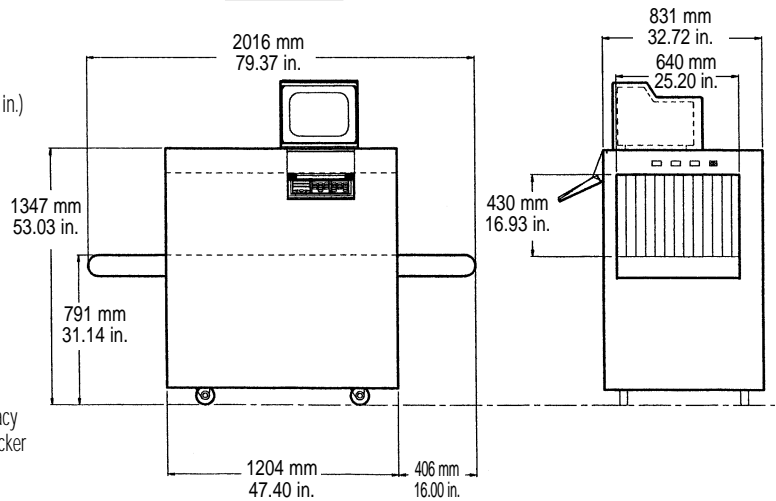

STANDARD FEATURES

- Crystal Clear™
- Multi Energy Imaging (4 color)
- Density Threat Alert
- Variable Edge Enhancement
- High/Low Penetration
- Variable Gamma
- Inverse Video
- Pseudo Color
- Variable Density Zoom
- Organic/Inorganic Stripping
- Black and White Viewing
- Variable Color Stripping
- 2, 4, 6, and 8 times Zoom
- View previous bag (up to 2 screens)
- Baggage Counter
- Search Indicator
- Date/Time display
- Full diagnostic built in test facility

OPTIONS

- Enhance Performance X-ray (EPX)
- Operator Training Program
- Threat Image Projection (TIP)
- TIP Network
- Target - Screener Assist Technology
- Manual Image Archiving
- Automatic Image Archiving
- VCR Output
- Video Printer
- Power Conditioner
- Operator Console
- Secure Workstation
- Remote Workstation
- Baggage Handling Accessories
- Foot-mat
- UPS (Uninterrupted Power Supply)
- High Speed Conveyor
- Plexi-Glass Tunnel Covers

Rapiscan Security Products



An OSI SYSTEMS Company

www.rapiscan.com

USA

3232 W. El Segundo Blvd.
 Hawthorne
 California 90250
 USA
 Tel: (310) 978-1457
 Fax: (310) 349-2491
 E-mail: sales@rapiscan.com

UK

Unit B1, The Fleming Centre
 Fleming Way
 Crawley, West Sussex
 England, RH10 9NN
 Tel: 44 (0) 1293-540661
 Fax: 44 (0) 1293-542019

Middle East (Service)

PO Box 9197
 Al Jadaf Port
 Shed DY 14
 Dubai
 United Arab Emirates
 Tel: 971-4-3240430
 Fax: 971-4-3240353

Asia Pacific

240 Macpherson Road
 #06-04 Pines Industrial Building
 Singapore 348574
 Tel: 65-6743-9892
 Fax: 65-6743-9885 / 6743-9915